



A PHYSICAL SECURITY TECHNOLOGY NEWSLETTER

SECURITYFACTS



IN THIS ISSUE:

FF-L-2740B AND ITS LOCKS

SF 700 IS REQUIRED

GSA REALIGNMENT ANNOUNCEMENT

WE'VE MOVED!

THE DOD LOCK PROGRAM WEBSITE HAS A NEW LOOK

THE WILL-BURT COMPANY

MILLENNIUM METALS, INC. CHANGES NAME
TO A&H SECURITY CABINETS, INC.

PLEASE CONTACT THE DOD LOCK PROGRAM IF YOU HAVE A
GSA-APPROVED CONTAINER MANUFACTURED BY FEDSAFES

CLASS 5-W WEAPONS CONTAINERS AVAILABLE THROUGH GSA

ELECTRONIC NEWSLETTER

SOME THINGS ARE STILL FREE!

DOD LOCK PROGRAM TRAINING

2014 EVENTS

FREQUENTLY ASKED QUESTIONS

ASSISTANCE & INFORMATION CONTACTS

FF-L-2740B AND ITS LOCKS

The threat of robotic dialing of mechanical combination locks drove the General Services Administration (GSA) to create the first Federal specification for "Locks, Combination," FF-L-2740, on 12 October 1989. The first lock approved under this new specification was the Mas-Hamilton Model X-07, an electromechanical lock.

After nearly 20 years of experience with these locks, the government saw the need to revise the specification. Revision FF-L-2740B was released on 15 June 2011. Its title is "Locks, Combination, Electromechanical," because a completely mechanical lock could not meet all requirements of the specification. Also, this clarified focus allows the specification to address particular concerns relating only to electromechanical locks.

Due to the technology advances with locking systems that protect National Security Information (NSI), interoperability, and possible restrictions that battery operated systems might impose on some areas of the government, GSA decided to categorize 2740B locking systems within the specification in order to allow the end users to determine proper use.

Government agencies must decide which Style of lock is/are appropriate for use in a given situation.

(Continued on page 2)



SECURITY FACTS



FF-L-2740B defines two distinctly different Styles of locks, based on power source and interoperability:

- *Style 1 lock is a basic self-contained lock; its power source is internal, such as a generator. It is not interoperable with any other device or equipment.*
- *Style 2 lock may have a removable power source, such as a battery. It may be interoperable or networked to other devices or equipment.*

Other changes of interest in Revision B include:

- *A Limited Use Statement, that is, use by authorized government or government contractor personnel only.*
- *U.S.-made electronic components are to be used to the maximum extent possible, and any foreign-made components must be declared to GSA.*
- *The lock's software must be controlled, its integrity will be verified, and it must meet FIPS (Federal Information Processing Standards) encryption requirements.*
- *Manufacturers are required to have a Top Secret facility security clearance.*



**Kaba Mas
Model X-10 View 1**



**Kaba Mas
Model X-10 View 2**



**Sargent & Greenleaf
Model 2740B View 1**



**Sargent & Greenleaf
Model 2740B View 2**

The latest Qualified Products List, QPL-FF-L-2740-10, 25 November 2013, lists the qualified products that are available for procurement. An approved lock is now available in each Style:

Style 1: Kaba Mas Model X-10	Power source: generator	Not interoperable
Style 2: S&G Model 2740B	Power source: batteries	Not interoperable





SF 700 IS REQUIRED

Information recorded on the Standard Form 700 (SF 700), "Security Container Information" has a vital role in maintaining the security, integrity and usability of GSA-approved containers and vault doors by documenting the contact information for authorized custodians and the current combination of the lock on the container, vault door or secure room storing classified material.

If a container, vault door or secure room storing classified material is found improperly secured, the information recorded on this form is used to contact the persons with authorized access so they can take immediate and appropriate action.

Additionally, having a record of the combination can prevent inconvenient and costly lockouts. For example, if circumstances were to occur that left the container without a custodian, the person taking charge of it would need to have it forced open—drilled or cut—to gain access. Not only would the contents be unavailable until the container was forced open, but other expenses would be incurred as well. For example, the cost of the opening, the cost of a new drawer or drawerhead, the potential expense of interim alternate storage arrangements, as well as repair or drawerhead installation costs.

DoDM 5200.01-V3 (February 24, 2012), Incorporating Change 2 (March 19, 2013), Enclosure 3, 10. SECURITY CONTAINER INFORMATION reads:

Maintain a record for each container, or vault or secure room door, used for storing classified information. SF 700 **with all information blocks completed**, shall be used for this purpose. Update the form each time the security container combination is changed.

SF 700 Instructions:

1. Complete Part 1, detach, and insert Part 1 in an opaque envelope (not provided with SF 700). Part 1 is unclassified, but contains personally identifiable information (PII) that shall be protected by sealing it in an opaque envelope. See Privacy Act Statement on reverse

side of Part 1 of the SF 700.

2. Seal and conspicuously mark the opaque envelope with "Security Container Information," and tape the opaque envelope to the inside of the control drawer of the security container.

3. Complete Part 2 (envelope) and Part 2A (end of flap).

4. Mark Part 2 and Part 2A with the highest classification level stored in this container. Include a classification authority block on Part 2 and Part 2A as follows: "Derived From: 32 CFR 2001.80(d)(3)," with declassification upon change of combination.

5. Detach Part 2A and insert in the Part 2 envelope and seal.

6. **Important:** Store completed SF 700, Part 2 and Part 2A in a separate security container authorized for storage at least equal to the highest level of the material the combination is protecting.

GSA-approved containers and vault doors securing arms, ammunition, and explosives (AA&E) are likewise required to have their custodian contact information and combination recorded on SF 700, per DoDM 5100.76 (April 17, 2012), Enclosure 4, 10. c. KEY, COMBINATION, AND LOCK CONTROL. This provides the same advantages as when the SF 700 is used for classified containers.

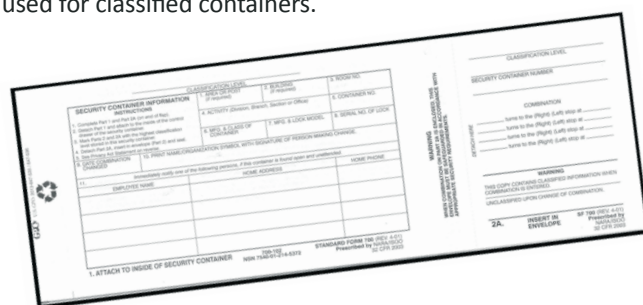

SF 700 may be ordered through the Supply System, using National Stock Number (NSN) 7540-01-214-5372

For specific guidance on completing the form, call the DoD Lock Program Technical Support Hotline at 1-800-290-7607, DSN: 551-1212 or go to our website at: <http://www.navfac.navy.mil/go/locks>. 

SECURITY FACTS



GSA REALIGNMENT ANNOUNCEMENT

During the winter of 2013/2014, GSA expects to transition the Security Equipment Program from the Multiple Award Schedule Program to the Global Supply Program. This realignment will provide full-service acquisition management support for your acquisition of GSA-approved Security Containers and Vault Doors. Advantages of this full-service program include:

- *Clear - Standardization of item descriptions*
- *Safe - All items meet rigid Federal Specifications and FAR procurement requirements*
- *Cost-Effective - Products are competitively priced*
- *Simple - See it, Buy it, Get it*
- *Flexible Ordering - Order online, by phone, fax or FEDSTRIP/MILSTRIP*
- *Flexible Payment - Payment options include purchase card or AAC/DoDAAC*

GSA establishes and publishes standards and specifications, tests and approves vendors to supply containers and vault doors, and is the vehicle for purchase of GSA-approved products. These GSA-approved security containers and vault doors are intended for the protection and storage of Classified National Security Information (NSI) (TOP SECRET, SECRET, and CONFIDENTIAL), and weapons.

More than 250 National Stock Numbers are assigned for the following products:

- *Filing Cabinets (Legal and Letter Size): 1-drawer, 2-drawer, 4-drawer and 5-drawer*
- *Map and Plan Containers*
- *Weapons Containers*
- *Shipboard Containers*
- *Field Safes*
- *Armory vault doors, ballistic vault doors, security vault doors*

Items above have been tested and verified by GSA to conform to one of the following Federal Specifications: AA-F-358, AA-F-363, AA-C-2786, AA-C-2859, and AA-D-600.

Under the new program, you must place your orders through GSA Global Supply using the assigned NSNs in order to receive a GSA-approved product. Please refer to the following web page for more information and points of contact as this program becomes active: <http://gsa.gov/portal/content/170591>. 



WE'VE MOVED!

If you attempt to get to our site using our old link (perhaps marked in your "Favorites") you will see this notice. To get to our new site, simply click on the DoD Lock Program website link. Don't forget to bookmark our new site in your Favorites, and delete the bookmark for our old site.



THE DOD LOCK PROGRAM WEBSITE HAS A NEW LOOK

The DoD Lock Program website has a new look, and with it, a new method of navigating. The links on the left are the navigation tree node, which is basically laid out the same as the menus on our old website. When you click on a link in the tree, you "drill down" to all the nodes (links) below that link, and the tree menu will refresh accordingly.

The navigation tree works only in one direction, meaning that (in most cases) you cannot navigate back up to the parent tree node. You must use the "breadcrumb" links to navigate back up to a parent node. The breadcrumb navigation path is just below the NAVFAC/EXWC banner at the top of the page. The breadcrumbs are hyperlinks that also show you the path you followed to get to the particular page you were seeking.

Finally, the DoD Lock Program banner serves as the main link to our home page, and it appears on all pages of our website. It is recommended that you use the DoD Lock Program banner to "start over" when navigating deeply in the tree as this will be faster than traversing the breadcrumb path. Our home page is the best place to start navigating our new site.

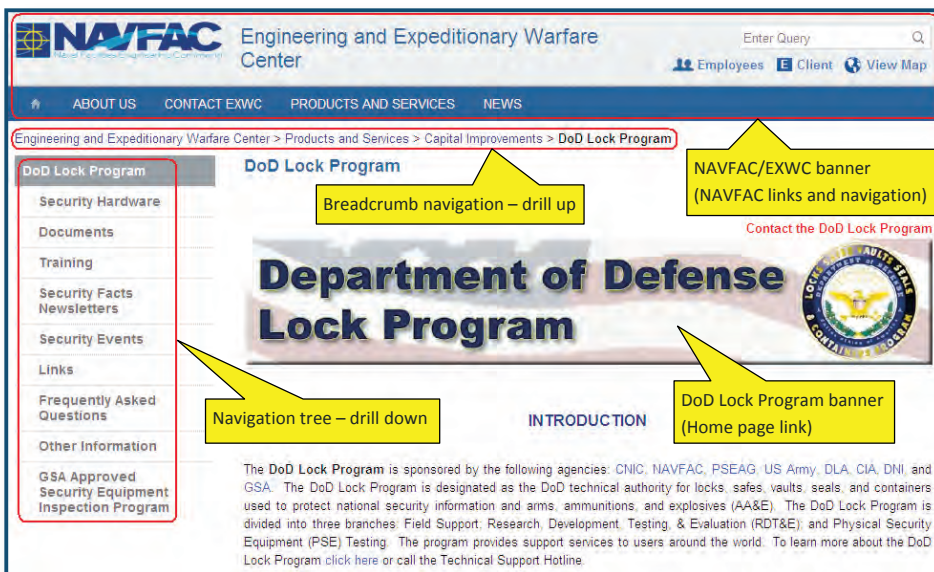

SECURITY FACTS

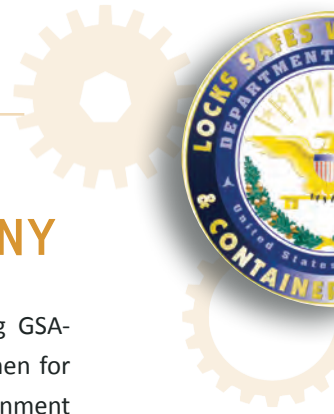

THE WILL-BURT COMPANY

The Will-Burt Company, which had been manufacturing GSA-approved security products for Mosler since 1996 and then for Diebold Mosler, has purchased the Diebold Mosler Government Products Division. The Will-Burt Company will continue to produce the same GSA-approved products, but their GSA approval labels (shown here) will now read “The Will-Burt Company.”

**GENERAL SERVICES ADMINISTRATION
APPROVED
SECURITY CONTAINER
THE WILL-BURT COMPANY**

For additional information about The Will-Burt Company products, contact the DoD Lock Program. 

MILLENNIUM METALS, INC. CHANGES NAME TO A&H SECURITY CABINETS, INC.

Millennium Metals, Inc. recently changed its name to A&H Security Cabinets, Inc. That name change is reflected in the current qualified products list and will appear on their products’ GSA labels.

Millennium Metals, Inc. of Burlington, KY, began manufacturing Class 6 GSA-approved containers in October 2009, soon after receiving GSA approval. A&H Security Cabinets, Inc. products can be found on the current qualified products list, QPL- AA-F-358-15, issued 12 September 2013. 





PLEASE CONTACT THE DOD LOCK PROGRAM IF YOU HAVE A GSA-APPROVED CONTAINER MANUFACTURED BY FEDSAFES

The DoD Lock Program is here to support all of your GSA-approved security equipment. Recently, it has come to our attention that FEDSAFES GSA-approved Class 5 security containers may have a condition that requires correction. The DoD Lock Program is gathering data for our records concerning these GSA-approved Class 5 security containers. If you have a FEDSAFES GSA-approved container, please contact the DoD Lock Program.

When you contact us, please provide the following information about your FEDSAFES container:

- *The type of container (2-drawer or 4-drawer)*
- *Single-lock or multi-lock*
- *The container serial number*
- *Whether the container already has a "repaired" label (shown here)*

Also, provide the name, phone number and email address of a point of contact for the container at your facility.

Call us at: 1-800-290-7607 or DSN: 551-1212,
or email us at: W_NAVFAC_DOD_Lock_Program_Support@navy.mil.

We appreciate your cooperation. 



GSA LABEL (FACSIMILE)



FEDSAFES REPAIRED LABEL

SECURITY FACTS



CLASS 5-W WEAPONS CONTAINERS AVAILABLE THROUGH GSA

For the first time, a Class 5 drawer-type weapons container is approved and labeled specifically for weapons storage. The new Class 5-W drawer-type weapons container is provided with an FF-L-2937 mechanical combination lock. This makes it a cost-effective alternative to a Class 5 container with an FF-L-2740 electromechanical lock, which is intended for storage of classified materials. Changes made in Revision J to Federal Specification AA-F-358, released 2 November 2010, show the new weapons container.

The current qualified products list, QPL-AA-F-358-15, dated 12 September 2013, lists Class 5-W weapons containers. These containers are manufactured by both Hamilton Products Group and The Will-Burt Company.

For additional information about Class 5-W weapons containers, go to the DoD Lock Program website at: <http://www.navfac.navy.mil/go/locks> or call the Technical Support Hotline at: 1-800-290-7607 or DSN: 551-1212.



ELECTRONIC NEWSLETTER

The DoD Lock Program's Security Facts Newsletter is available electronically. In addition to the considerable cost savings and diminished environmental impact, the electronic issues will be enhanced to offer easier navigation and additional links to the information you need.

To subscribe to the Security Facts Newsletter, use the "Security Facts Newsletter" link on our website. Click on "SFN request form," include your email address on the form and click "Submit." Each time we publish a newsletter, we will send you an email notification. Or you can send an email to: W_NAVFAC_DOD_Lock_Program_Support@navy.mil, and we will add you to our database.



SOME THINGS ARE STILL FREE!

Yes, the DoD Lock Program is still offering "Open/Secured" two-sided magnetic signs to the DoD community free of charge. And to help you find us, these signs include the Technical Support Hotline contact information and new DoD Lock Program web address for quick reference in getting the support you need for your security equipment.

It's good practice to use these signs on containers or vault doors in order to provide a visual status of the equipment to personnel in the area. To place your order, see the ad on our DoD Lock Program website home page, <http://www.navfac.navy.mil/go/locks> .



DOD LOCK PROGRAM TRAINING

Due to fiscal constraints and other factors, the DoD Lock Program will postpone training on the FF-L-2740 approved combination locks until further notice. This includes the Kaba Mas Model X-09, the Kaba Mas Model X-10, the Sargent and Greenleaf Model 2740, and any other locks that may be approved.

It is our goal to continue our FF-L-2740 training in the future. When we have a new schedule, notices will be posted on our website at: <http://www.navfac.navy.mil/go/locks>.



SECURITY FACTS



2014 EVENTS



May 5 – 10, 2014

SAVTA CONVENTION 2014

Safe & Vault Technicians Association (SAVTA)

Lexington, KY

For additional information,

visit their website:

<http://www.savta.org/>

July 19 – 26, 2014

TRADESHOW JULY 24 – 26

ALOA Convention 2014

Associated Locksmiths of America (ALOA)

New Orleans, LA

For additional information,

visit their website:

<http://www.aloa.org/>



September 29 – October 2, 2014

ASIS 2014 60TH ANNUAL SEMINAR & EXHIBITS

American Society for Industrial Security (ASIS)

Atlanta, GA

For additional information,

visit their website:

<http://www.asisonline.org/pages/default.aspx>

NOTE: Event dates subject to change. Please check websites above for the latest information.





FREQUENTLY ASKED QUESTIONS

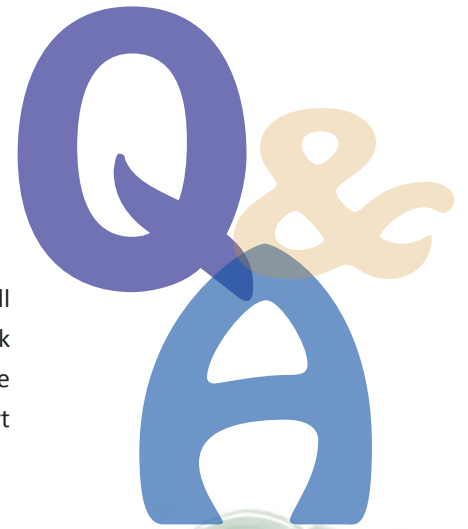

Q . What strike plate do I need with my new CDX-09

A . When you order a CDX-09 from DLA Troop Support (formerly DSCP) it will include a #1 strike plate. If you need a different strike plate, call the DoD Lock Program's Technical Support Hotline and one can be provided free of charge if your lock is purchased from DLA. Please contact the DoD Technical Support Hotline to determine the correct strike plate for your application.

Q . I'm having a problem with my X-09 combination lock. I enter the combination, dial right and "OP" is displayed. I continue dialing to the right indefinitely, but the lock doesn't unlock. What could be the problem, and what can I do about it?

A . The "OP" display means you've entered the correct combination (or combinations, if the lock is in dual mode) non-robotically. Remember to turn the dial with full wrist turns. This keeps the lock fully powered. The problem may be that the combo motor is an early version, which should be replaced.

- **TRY THIS:** Vary the speed of dialing after achieving the "OP" display. Dialing either more rapidly or more slowly will often retract the bolt.
- **OR TRY THIS:** After achieving "OP", begin striking the front of the container near the dial ring with a dead blow mallet **as you continue dialing to the right**. This may shake the combo motor loose so that it will operate as it receives electric power. Protect the surface of the container with a piece of cardboard.

If you are still unsuccessful, contact the DoD Lock Program Technical Support Hotline for assistance at: 1-800-290-7607 or DSN: 551-1212. 

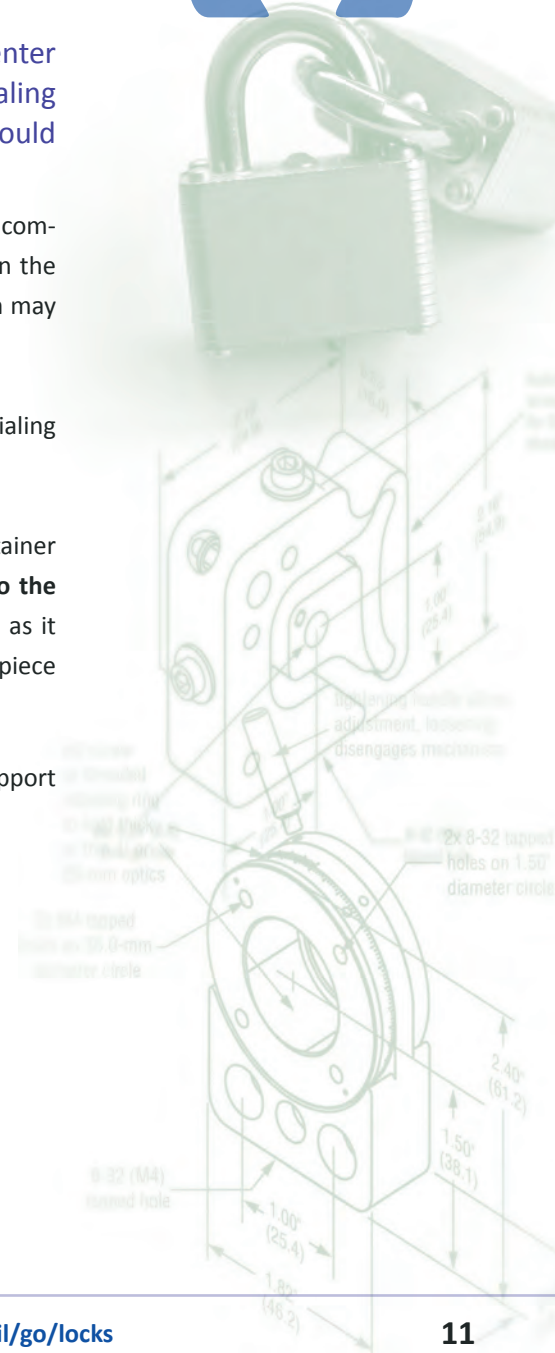

DEPARTMENT OF DEFENSE LOCK PROGRAM



DOD LOCK PROGRAM

The objective of the DoD Lock Program is to provide technical and management support for research, development, test, and evaluation of locking devices and related security systems used by the DoD. As such, the Program staff has considerable knowledge, skills, and abilities related to locking devices and security systems that can be of substantial value in providing guidance, solutions, and information on these products. The Technical Support Hotline is structured to provide quick and accurate answers to technical questions on hardware selection, requirements, training, specifications, stock numbers, and troubleshooting of equipment failures. The Hotline personnel are also knowledgeable on many other types of security equipment such as vehicle barriers, magazine doors, emergency destruct equipment, etc., and can often provide immediate guidance or at least get you headed in the right direction. Please call us today.

FOR ASSISTANCE OR INFORMATION CALL:

Technical Support Hotline:

Phones: 1-800-290-7607; 1-805-982-1212; DSN: 551-1212

FAX: 1-805-982-1253; DSN: 551-1253 or email:

W_NAVFAC_DOD_Lock_Program_Support@navy.mil

Please leave a commercial number for return calls.

Training Coordinator:

1-805-982-1575; DSN: 551-1575 or email:

W_NAVFAC_DOD_Lock_Program_TC@navy.mil

Drawer Head Replacement Information:

1-805-982-1153; DSN: 551-1153 or email:

W_NAVFAC_DOD_Lock_Program_Support@navy.mil

Field Support Branch Manager:

1-805-982-3558; DSN: 551-3558 or email:

W_NAVFAC_DOD_Lock_Program_Manager@navy.mil

DoD Lock Program Director:

1-805-982-2673; DSN: 551-2673 or email:

W_NAVFAC_DOD_Lock_Program@navy.mil

Subscribe to SECURITY FACTS newsletters: *If you would like to subscribe to the Security Facts newsletter, send an email to:*

W_NAVFAC_DOD_Lock_Program_Support@navy.mil *Include your name, address, phone, FAX, DSN, and email address.*

Enter "Subscribe to Security Facts" in the email subject field. Or, you may call our Technical Support Hotline at:

1-800-290-7607; 1-805-982-1212; DSN: 551-1212.



YOU SAVE TIME & MONEY WHEN YOU PURCHASE EQUIPMENT FROM THE DEFENSE LOGISTICS AGENCY

DLA Troop Support, Industrial Hardware, Philadelphia, PA sells a variety of physical security equipment (PSE). PSE available through the DoD Lock Program website includes products required for the protection of classified materials, and weapons and ammunition. Locate the PSE you need from our website. A DLA icon next to the item indicates that it is available from DLA.



Call the Technical Support Hotline to find out more about DLA and the products they sell.

DOD LOCK PROGRAM WEBSITE:

Remember to add the DoD Lock Program website home page to your favorites. You can find it at:

<http://www.navfac.navy.mil/go/locks>

SECURITY FACTS

Published by NAVFAC EXWC using appropriated funds

Capital Improvements Department Head.....1-805-982-1219

Physical Security Tech. Division Director 1-805-982-2673

DoD Lock Program Technical Manager 1-805-982-3558

Editor 1-805-982-1567



Naval Facilities Engineering & Expeditionary Warfare Center (NAVFAC EXWC)

Physical Security Technology Division

DoD Lock Program

1100 23rd Avenue

Port Hueneme, CA 93043-4370