

INCH-POUND

MIL-DTL-43607J
w/Amendment 1
29 JULY 2010
SUPERSEDING
MIL-DTL-43607J
5 JUNE 2007

DETAIL SPECIFICATION

PADLOCK, KEY OPERATED, HIGH SECURITY, SHROUDED SHACKLE

INACTIVE FOR NEW DESIGN AFTER 22 MAY 2000.

This specification is approved for use by all Departments and Agencies of the Department of Defense.

1. SCOPE

1.1 Scope. This specification covers a key operated, high security, shrouded shackle padlock that employs a dead bolt locking system. The padlock will have three different versions with varying cylinders and external markings as specified herein; all three versions will meet the requirements of this specification.

2. APPLICABLE DOCUMENTS

2.1 General. The documents listed in this section are specified in sections 3 and 4 of this specification. This section does not include documents cited in other sections of this specification or recommended for additional information or as examples. While every effort has been made to ensure the completeness of this list, document users are cautioned that they must meet all specified requirements documents cited in sections 3 and 4 of this specification, whether or not they are listed.

2.2 Government documents.

2.2.1 Specifications, standards and handbooks. The following specifications and standard form a part of this document to the extent specified herein. Unless otherwise specified, the issues of these documents are those cited in the solicitation or contract.

Comments, suggestions, or questions on this document should be addressed to Defense Supply Center Philadelphia (DSCP), ATTN: DSCP-NASA, 700 Robbins Avenue., Philadelphia, PA 19111-5096 or e-mail to dscpg&inspecomments@dla.mil. Since contact information can change, you may want to verify the currency of this address information using the ASSIST Online database at <https://assist.daps.dla.mil>.

MIL-DTL-43607J
w/Amendment 1

FEDERAL SPECIFICATION

RR-C-271 Chains and Attachments, Welded, Weldless.

DEPARTMENT OF DEFENSE SPECIFICATIONS

MIL-G-21164 Grease, Molybdenum Disulfide, for Low and High
Temperatures, NATO Code Number G-353.

MIL-H-24653 Hasp, High Security, Shrouded for Shipboard Doors and
Hatches using High and Medium Security Padlocks.

MIL-DTL-29181 Hasp, High Security, Shrouded, for High and Medium Security
Padlock

DEPARTMENT OF DEFENSE STANDARD

MIL-STD-889 Dissimilar Metals.

(Copies of these documents are available online at <https://assist.daps.dla.mil/quicksearch/> or from the Standardization Document Order Desk, 700 Robbins Avenue, Building 4D, Philadelphia, PA 19111-5094).

2.2.2 Other Government drawings. The following other Government drawings form a part of this document to the extent specified herein. Unless otherwise specified, the issues are those cited in the solicitation or contract.

DRAWINGS

NAVAL SEA SYSTEMS COMMAND (NAVSEA)

53711-5532334 High Security Hasp, MK 2 MOD 9 Hinged or Sliding
Horizontal Door, R. H., Style 1.

53711-5532335 High Security Hasp, MK 2 MOD 9 Hinged or Sliding
Horizontal Door, L. H., Style 2.

53711-5532337 High Security Hasp, Shipboard, 1300 MOD 1.

53711-5532340 Universal Security System Sliding Door.

NAVAL AMMUNITION PRODUCTION ENGINEERING CENTER (NAPEC)

0955 High Security Hasp, Hinged R. H., MK 2 MOD 7.

0956 High Security Hasp, Hinged or Sliding Horizontal Door, R.H.,
MK 2 MOD 8.

MIL-DTL-43607J
w/Amendment 1

0957	High Security Hasp, Hinged or Sliding Horizontal Door, R.H., MK 2 MOD 8.
0958	High Security Hasp, Hinged or Sliding Horizontal Door, L.H., MK 2 MOD8.

(Copies of drawings required by contractors in connection with specific acquisition functions should be obtained from the procuring activity or as directed by the contracting officer.)

2.3 Non-Government publications. The following documents form a part of this document to the extent specified herein. Unless otherwise specified, the issues of these documents are those cited in the solicitation or contract.

AMERICAN SOCIETY FOR QUALITY (ASQ)

ASQ Z1 .4 Sampling Procedures and Tables for Inspection by Attributes.

(Copies of this document are available from www.asq.org or the American Society for Quality, 600 North Plankinton Avenue, Milwaukee, WI 53203.)

ASTM INTERNATIONAL

ASTM B 117 Salt Spray (Fog) Testing, Standard Test Method for.
ASTM E 18 Materials, Metallic, Rockwell Hardness and Rockwell Superficial Hardness of.

(Copies of these document are available from www.astm.org or ASTM International, 100 Barr Harbor Drive, West Conshohocken, PA 19428-2959.)

SOCIETY OF AUTOMOTIVE ENGINEERS (SAE)

AMS-M-7866 Molybdenum Disulfide, Technical, Lubrication Grade
AMS-QQ-N-290 Nickel Plating (Electrodeposited)
AMS-QQ-C-320 Chromium Plating (Electrodeposited)

(Copies of these documents are available from www.sae.org or the Society of Automotive Engineers, Inc., 400 Commonwealth Drive, Warrendale, PA 15096-0001.)

2.4 Order of precedence. In the event of a conflict between the text of this document and the references cited herein, the text of this document takes precedence. Nothing in this document, however, supersedes applicable laws and regulations unless a specific exemption has been obtained.

3. REQUIREMENTS

MIL-DTL-43607J
w/Amendment 1

3.1 Bid sample. Unless otherwise specified (see 6.2), each bidder shall furnish the following with the bid:

- a. 17 samples of the padlock with key sets for inspection as specified in 4.2.1.
- b. 24 milled, uncut key-blanks for testing.

One intact unit of the selected product will be retained by the testing agency and one intact unit will be returned to the selected bidder to be used as a guide in manufacturing the first article and production quantity (see 3.2).

3.2 First article. Unless otherwise specified (see 6.2), seven padlocks and key sets shall be furnished for first article testing and approval (see 4.1 and 6.3). If the requirement for bid samples is waived, 17 padlocks and key sets shall be furnished for the first article testing and approval. In addition, unless otherwise specified (see 6.2), 24 milled, uncut key-blanks shall be furnished for testing. The first article units shall be selected at random from the first 100 standard production units or from the contractor's current inventory. If approved, one intact unit of the first article submission will be forwarded to the cognizant quality assurance representative. One intact unit shall be returned to the contractor to serve as the manufacturing standard. No deviation from the manufacturing standard shall be acceptable without formal written approval of the contracting officer in advance. Certification of compliance with this paragraph shall be provided to the inspector with each production quantity lot presented for inspection and acceptance.

3.3 Materials. Materials used shall be free from defects which would adversely affect the performance or maintainability of individual components or of the overall assembly. Materials not specified herein shall be of the same quality used for the intended purpose in commercial practice. Unless otherwise specified herein, all equipment, material, and articles incorporated in the work covered by this specification are to be new and fabricated using materials produced from recovered materials to the maximum extent possible without jeopardizing the intended use. The term "recovered materials" means materials which have been collected or recovered from solid waste and reprocessed to become a source of raw materials, as opposed to virgin raw materials. Unless otherwise specified, none of the above shall be interpreted to mean that the use of used or rebuilt products is allowed under this specification.

3.3.1 Material deterioration and control. The padlock shall be fabricated from compatible materials, inherently corrosion- and deterioration-resistant or treated to provide protection against various forms of corrosion and deterioration. This treatment shall provide protection that may be encountered in any of the applicable storage and operating environments to which the padlock may be exposed.

3.3.1.1 Dissimilar metals. Dissimilar metals, as defined in MIL-STD-889, shall be coated, plated, or electrically insulated from one another to minimize or prevent galvanic corrosion.

MIL-DTL-43607J
w/Amendment 1

3.3.1.2 Identification of materials and finishes. The contractor shall identify the specified material, material finish, or treatment used for, on, or between components and sub-components, and shall make information available, upon request to the contracting officer or designated representative.

3.3.1.3 Recycled, recovered, or environmentally preferable materials. Recycled, recovered, or environmentally preferable materials should be used to the maximum extent possible provided that the material meets or exceeds the operational and maintenance requirements, and promotes economically advantageous life cycle costs.

3.4 Design. The major components of the padlock shall be a body, a shackle, and a locking mechanism. The term shackle as used herein also includes a sliding pin or bar if so designed. The pin or bar is the part that passes through the locking hole of the mating halves of hasps such as the shackle does. The shape of the padlock shall be at the option of the contractor, provided the assembled padlock conforms to all requirements specified herein. The shackle shrouding created by body extensions shall have a closely-fitted top opening for shackle clearance when the padlock is in the unlocked fully open position. The shackle shrouding shall have a side opening that will admit the mating members of hasps conforming to MIL-H-24653, MIL-DTL-29181, NAVSEA drawings 53711-5532337, 53711-5532340, 53711-5532334, 53711-5532335, and NAPEC drawings 0955, 0956, 0957, and 0958. The locking of the padlock on the above described hasps shall be accomplished by either turning the key or pushing the body into the shackle and turning the key without the assistance of blocking or spacers between the shackle and the hasp guard. The padlock shall lock the mating members of the hasps specified herein when the hasps are mounted as specified in the installation instructions of the specified hasps. The assembled padlock, excluding the chain, clevis, and plate shall have a volume that is not more than 20 cubic inches (328 cubic centimeter (cm)), and a weight that is not more than 6 pounds (lb) (3.0 kilogram (kg)). See figure 1 for examples of padlocks with a shrouded shackle.

3.4.1 Keys and keyways. There shall not be less than 100,000 different key changes for padlocks supplied under any one contract.

3.4.1.1 Military version. The key section and keyway design shall be configured exclusively for military use, and shall not be available commercially. The key section and keyway design, and the reverse image of the design, shall be reserved for DoD use only.

3.4.1.2 Government version. The key section and keyway design shall be configured exclusively for government and government contractor use. The key section and keyway shall be controlled at the factory level and shall not be available commercially.

3.4.1.3 Foreign military and commercial version. The key section and keyway shall be commercially available with no restrictions.

MIL-DTL-43607J
w/Amendment 1

3.4.2 Chain, clevis, and plate. A chain, attachment plate, and clevis shall be furnished with each padlock. The chain shall be securely attached to the padlock case by means of a clevis and rivet or other secure fastening device, in such a manner that it will not interfere with the operation of the locking mechanism. The chain length shall be 9 inches (229 millimetre (mm)) plus or minus one link. Chain, clevis, fastener, screws, and plate shall be fabricated from corrosion-resisting material. The chain shall be attached to the lock in such a manner that the key opening and drain holes shall perform their proper function. The chain shall conform to RR-C-271, type I, grade C, class 5, style 1.

3.5 General requirement. The padlock shall meet general requirements as specified in 3.5.1 through 3.5.3.

3.5.1 Surreptitious neutralization resistance. The padlock shall resist surreptitious neutralization for not less than 15 minutes before and after the wear resistance cycling (see 3.5.2.1 and 4.5.1.1).

3.5.2 Effectiveness of design and materials durability. The design features and the materials used shall be such that the padlock shall perform as specified in 3.5.2.1 through 3.5.2.9.

3.5.2.1 Wear resistance. The padlock shall withstand 10,000 complete locking and unlocking cycles, without failure to fully lock and fully unlock during any cycle, and without loss of resistance to surreptitious neutralization (see 4.5.1.2).

3.5.2.2 Drop resistance, ambient temperature. The locked padlock shall withstand not less than 10 consecutive drops on different sides, from a height of not less than 6 feet (ft) (1.83 meter (m)), onto a hard, unyielding surface without exhibiting evidence of fracture of any component or malfunction (see 4.5.1.3).

3.5.2.3 Drop resistance, high temperature. The locked padlock shall not be affected from being dropped from a height of not less than 3 ft (0.9 m) onto a hard unyielding surface. The padlock shall not open by means other than with the proper key. The padlock is to be dropped while it is still hot from having been heated to a temperature of not less than 1200 degrees Fahrenheit (°F) (649 degrees Celsius (°C)) (see 4.5.1.4 and 4.5.1.7).

3.5.2.4 Shackle pull-out resistance. The padlock shall resist a tensile pull of not less than 12,000 pound-force (lbf) (53 378 Newton (N)) on the shackle without pulling the shackle out of the padlock (see 4.5.1.5).

3.5.2.5 Shackle resistance, low temperature. The padlock shall resist opening by means other than by the proper key after being cold soaked a minimum of 1 hour at -100°F (-73°C) and being struck with a 3 lb (1.36 kg) double faced engineers hammer. This performance is required while the padlock is secured in the locked mode on a MIL-DTL-29181 hasp in a vertical wall mount position (see 4.5.1.6).

3.5.2.6 Forced entry resistance.

MIL-DTL-43607J
w/Amendment 1

3.5.2.6.1 Non battery powered tools. The padlock shall withstand a concentrated forced entry attack using non battery powered tools for an accumulated work time of at least five minutes (see 4.5.1.7.1).

3.5.2.6.2 Battery powered tools. The padlock shall withstand a concentrated forced entry attack using battery powered tools for an accumulated work time of at least one minute (see 4.5.1.7.2.).

3.5.2.7 Heat resistance. The padlock shall withstand a direct pull of not less than 50 lbf (222 N) on the shackle after exposure to a temperature between 1875°F (1023°C) and 1925°F (1051 °C), without opening or separation of the shackle (see 4.5.1.8).

3.5.2.8 Low temperature operation. The padlock shall be operated at $-60^{\circ}\text{F} \pm 2^{\circ}\text{F}$ ($-51^{\circ}\text{C} \pm 1^{\circ}\text{C}$) when the appropriate operating key is inserted and turned in the padlock. The cylinder shall turn without sticking or excessive force or pressure and release the shackle both when initially tested and after 10,000 cycles. The control key shall also perform its design function without sticking or excessive pressure or force before and after the 10,000 cycle test (see 4.5.1.9).

3.5.2.9 Salt spray (fog) resistance. The padlock and its keys shall withstand exposure to salt spray (fog) for not less than 96 hours without exhibiting evidence of deterioration of any component, except for minor corrosion that does not adversely affect the performance of the padlock and keys (see 4.5.1.11).

3.5.3 Key integrity. The keys furnished with any padlock shall be not capable of locking, unlocking, or removing the cylinder of any other padlock (see 4.5.1.10).

3.6 Detailed requirements. The padlock, components, and keys shall be as specified in 3.6.1 through 3.6.4.1.

3.6.1 Body. The complete assembled body of the padlock shall have no openings other than shackle opening and keyway, except that drainage holes and plugged holes are permissible. Drainage holes, if incorporated, shall be not larger than 0.093 inches (2.40 mm) diameter. The body shall incorporate a means to prevent access to the locking mechanism, except by use of a control key or by disassembly of the padlock.

3.6.2 Shackle. The shackle shall be 0.50 +0.002 -0.010-inch (12.7 + 0.05 -0.254 mm) diameter. The shackle shall remain securely attached when the padlock is in the unlocked, fully opened position and shall be capable of being separated from the padlock only when the padlock is disassembled.

3.6.3 Locking mechanism. The shackle shall be held in the locked position by a dead-bolt type lock mechanism. The padlock shall open when the key is turned in the clockwise direction and lock when the key is turned in the counterclockwise direction. The operating key shall be retained in the keyway of the cylinder and shall not be removable when the padlock is in the open position.

3.6.3.1 Cylinder assembly. The cylinder assembly of the locking mechanism shall have a plug with only three distinct, easily recognizable, positions. Two positions of the plug shall be operating

positions of locked and unlocked. The third position shall be the control position which allows disassembly of the lock.

3.6.3.2 Cylinder assembly removal. The cylinder assembly shall be securely retained within the padlock body when the cylinder plug is in either the locked or unlocked position. The cylinder assembly shall be removable from the padlock body only after the cylinder plug is rotated to the control position by use of a control key. When removed from the padlock body, the cylinder assembly shall remain as one assembly (see 4.5.1.15).

3.6.3.3 Cylinder assembly interchangeability. A cylinder assembly from any one padlock delivered under a contract shall be interchangeable with a cylinder assembly from any other padlock delivered under the same contract (see 4.5.1.16).

3.6.3.4 Key. The padlock shall be furnished with three keys, consisting of two operating keys and one control key. Terms for parts of keys and padlocks used herein are defined below and shown on figure 2. However, the illustrations shown in figure 2 are not intended to restrict the use of other types of keys.

Bow	The handle, or head of a key. On a cylinder key, that part beyond the shoulder that does not enter the keyway and by which the key is held and turned.
Blade	Part that is inserted into the lock cylinder keyway.
Bit	The section of a key that enters a lock, which has the key cuts formed in it and which engages the bolt or tumblers of the lock. The bit is called a blade in the case of a cylinder lock.
Key Cut	A square, rounded, or V-shaped depression, filed or machined into a key. In tumbler locks, the series of key cuts on a key causes the tumblers to line up at the shear line or gate so that the lock will open. In warded locks, the key cuts bypass the wards so the key can push or pull the bolt.
Key Section	The shape of a key blade in cross section, viewed in the plane perpendicular to the length of the blade. The key section is determined by the shape of the keyway it fits.

3.6.3.5 Key material hardness. All components parts of the key shall have a hardness not less than 75 HRB in accordance with ASTM E 18 (see 4.5.1.12).

3.6.3.6 Key strength. Keys shall have sufficient strength to ensure against premature failure in service. This strength shall be measured by the test in 4.5.1.13. That test requires the key to withstand 9 pound-force inch (lbf-in) (1 Newton metre (Nm)) of torque applied to the key's deepest cut (smallest cross-sectional area) for 30 seconds.

3.6.3.7 Key deformation resistance. The key shall resist a torque of 9 lbf-in (1 Nm) without permanent set deformation of more than 0.125-inch (3.2 mm), when measured at the end of an 8-inch (203 mm) lever. The lever shall be attached to the bow of the key blank at an angle perpendicular to

MIL-DTL-43607J
w/Amendment 1

the long axis of the blade of the key blank. The maximum cross section of the material being torqued shall be no greater than the cross section at the deepest bit cut employed (see 4.5.1.13).

3.6.3.8 Key shapes. The bows of the operating keys shall be identical. The bows of control keys shall be of significantly different shapes than the bows of the operating keys.

3.6.3.9 Key bit cut limits. Test results from key deformation resistance test (3.6.3.7) shall be used to determine the safe key cut limits at any point on the blade to sustain the 9 lbf-in (1 Nm) torque required in 4.5.1.13.

3.6.3.10 Key markings. Keys shall be identifiable by the factory markings. Control keys for all versions shall be marked with: "CONTROL KEY".

3.6.3.10.1 Military keys. Operating and control keys shall be marked with: "US MILITARY PROPERTY DO NOT DUP."

3.6.3.10.2 Government keys. Operating and control keys shall be marked with: "R-1 DO NOT DUP."

3.6.3.10.3 Foreign military and commercial. Operating and control keys shall be marked with: "S-1."

3.6.3.11 Operating keys. The operating keys shall lock and unlock the padlock. The operating keys shall not be capable of rotating the cylinder plug to the control position. When the cylinder plug is in the unlocked position, the operating key shall be prevented from being removed from the cylinder plug (see 4.5.1.14).

3.6.3.12 Control key. The control key shall lock and unlock the padlock, and also rotate the cylinder plug to the control position to enable removal of the cylinder as specified in 3.6.3.2 (see 4.5.1.15).

3.6.3.13 Key serial numbers. Serial numbers of keys shall be placed on a metal tag affixed to the key ring. The serial number shall not be stamped or appear anywhere on the key. The serial number shall be stamped on the tag with characters not less than 0.094-inch (2.38 mm) in height. The serial number shall not in any way disclose the key biting either directly or by commercially available or published coding.

3.6.4 Appurtenances, slides, or covers. Appurtenances, slides, or covers that may be incorporated in the padlock shall be secure when the locking mechanism is in the locked or unlocked positions. The removal of any appurtenance, slide, or cover shall not be possible, except with the control key in the control position or by disassembly of the padlock (4.5.1.1).

3.6.4.1 Keyway cover. Any keyway cover or plate shall remain aligned with the keyway. There shall be no keyway cover or obstruction which requires any special action or separate maneuver by the padlock user before a key can be inserted in the keyway (see 4.5.1.14).

MIL-DTL-43607J
w/Amendment 1

3.7 Lubrication. The padlock shall be lubricated with molybdenum disulfide powder conforming to AMS-M-7866 applied sparingly to the internal parts of the cylinder. Other moving parts may be lubricated by applying a thin film of lubricant conforming to MIL-G-21164.

3.8 Color and finish. The color of the padlock shall be the natural color of the finish. All surfaces shall have a uniform finish of sufficient smoothness to accept the required marking. When corrosion protection is required for the padlock body or shackle, the finish shall be limited to chromium plating in accordance with AMS-QQ-C-320, class 1, type II, or nickel plating in accordance with AMS-QQ-N-290, class 2 except that the finish shall be dull or satin.

3.9 Identification markings. All versions of the padlock shall bear the manufacturer's name or trademark, some traceable model identification, and the year of manufacture. There shall be no markings on the padlock exterior which would aid in the unauthorized opening of the padlock. All markings may be stamped, rolled, cast, or applied in any other manner that will ensure legibility after the padlock has been exposed to the testing specified.

3.9.1 Military and government version. In addition to the markings identified in 3.9, the body of the padlock shall be marked "US GOVERNMENT PROPERTY".

3.9.2 Foreign military and commercial version. In addition to the markings identified in 3.9, the body of the padlock shall not be marked to indicate the padlock is the property of the US government (e.g. US, US government, etc.).

3.10 Instructions. Operating and maintenance instructions shall be furnished with each padlock.

3.11 Workmanship. The padlock and keys shall be free from sharp edges, burrs, and slivers that affect serviceability or appearance.

4. VERIFICATION

4.1 Classification of inspections. The inspection requirements specified herein are classified as follows:

- a. Bid sample inspection (see 4.2).
- b. First article inspection (see 4.3).
- c. Conformance inspection (see 4.4).

4.2 Bid sample inspection. Bid sample inspections shall be conducted by agencies as specified in the contract. Samples selected shall be at manufacturer's option (see 3.1).

MIL-DTL-43607J
w/Amendment 1

4.2.1 Bid sample examination. Bid sample padlocks shall be examined for defects. The presence of any visual defect, any dimensions not within specified requirements, or failure to pass any test shall be cause for rejection of the bid. Bid sample padlocks, after inspection, shall be handled as specified in 3.1 unless otherwise specified in the contract. Bid samples shall be preproduction or standard production units from the contractor's current inventory.

4.2.2 Bid sample tests. Bid sample padlocks shall be tested in accordance with 4.5.1.

4.3 First article inspection.

4.3.1 Sampling for first article. When a first article is required (see 3.2 and 6.2), 7 sample units shall be provided for inspection. When the requirement for bid samples is waived, 17 units shall be provided for inspection, plus 24 milled, uncut key-blanks. The 7 first article units shall be taken from the first 100 standard production units or from the contractor's current inventory or shall be exactly the same as accepted bid samples set aside for production samples. First article units, after inspection, shall be handled as specified in 3.2 unless otherwise specified in the contract.

4.3.2 First article examination. The first article shall be examined as specified in 4.5.1. Presence of one or more defects shall be cause for rejection (see 3.2).

4.3.3 First article tests. The first article shall be subjected to the tests as specified in 4.5.1. Failure of any test shall be cause for rejection (see 3.2).

4.4 Conformance inspection.

4.4.1 Sampling.

4.4.1.1 For examination. Sampling for examination shall be in accordance with ASQ Z1.4. Guidance for inspection level with zero percent defect is provided in 6.4.1. The lot shall be units produced at the same plant, by the same process, with same materials, and of the same design, all offered for delivery at one time, not greater than 5,000 units per lot.

4.4.1.2 For tests. Padlocks shall be randomly selected from the lot submitted for acceptance in accordance with ASQ Z1.4. Guidance for inspection level is provided in 6.4.2.

4.4.2 Examination. Samples selected in accordance with 4.4.1.1 shall be examined for defects as specified in 4.5.1. Presence of any critical defect shall be cause for rejection.

4.5 Inspection procedure. Prior to examination and tests, padlocks shall be lubricated and, unless otherwise specified herein, all tests shall be performed in the order shown.

4.5.1 Test procedures.

4.5.1.1 Surreptitious neutralization test. The test shall be conducted with the padlock at room

MIL-DTL-43607J
w/Amendment 1

temperature, $70^{\circ}\text{F} \pm 10^{\circ}\text{F}$ ($21^{\circ}\text{C} \pm 5^{\circ}\text{C}$). Subject the locked padlock to surreptitious attempts to open the padlock, without the furnished keys. These methods shall include use of devices, equipment and methods such as picking, shimmiing, bypassing, impressing, and other methods used by locksmiths to open padlocks. These methods which are used to open the padlock without evidence of attempts to open or harm the padlock shall be conducted for not less than 15 minutes. If the padlock is opened by any of the surreptitious techniques in less than 15 minutes, it shall constitute failure of this test. In addition, if any appurtenance, slide, or cover is rendered insecure, or is removed by surreptitious neutralization, it shall constitute failure of this test (see 3.5.1 and 3.6.4).

4.5.1.2 Wear resistance test. Use the control key to remove and replace the cylinder assembly in the padlock. Place the cylinder plug in the locked position (shackle, bar, or pin in closed position) and withdraw the control key. Use an operating key to subject the padlock to 10,000 complete consecutive cycles of unlocking and locking. A single cycle shall include the following steps:

- a. Insert operating key into keyway and use it to rotate cylinder plug to unlocked position. The bar or pin of the sliding bar or pin type shall move to the open position by the rotation of the cylinder plug to the unlocked position.
- b. Pull shackle fully open and reclose shackle.
 - (1) This step does not apply to the sliding bar or pin type.
- c. Rotate cylinder plug with operating key to locked position and pull on shackle to ensure it is locked.
 - (1) For the sliding bar or pin type, the bar or pin shall have been pushed by a cam on the cylinder plug to the locked position.
- d. Remove the operating key from the keyway.

After the 10,000 cycles are completed, conduct the surreptitious neutralization test specified in 4.5.1.1 on the same padlock used in the wear test. Then, use the control key to remove and replace the cylinder assembly again. If the padlock malfunctions during the 10,000 cycles, fails the surreptitious neutralization test after the 10,000 cycles, or does not permit removal and replacement of the cylinder by use of the control key, any one of these shall constitute failure of this test (see 3.5.2.1).

MIL-DTL-43607J
w/Amendment 1

4.5.1.3 Drop test, ambient temperature. The test shall be conducted with the padlock at room temperature, $70^{\circ}\text{F} \pm 10^{\circ}\text{F}$ ($21^{\circ}\text{C} \pm 5^{\circ}\text{C}$). The surface on which the padlock shall be dropped, shall be 0.5-inch (12.7 mm) thick steel plate fastened to a Portland cement concrete base. The padlock shall be locked and dropped not less than 10 times from a height of 6 feet (1.83 m) onto the steel plate. The drops shall be free drops, but manipulated so that the padlock strikes the steel surface not less than once on each of its six major surfaces (i.e., top, bottom, front, back, and both sides). After the 10 drops, unlock the padlock with the control key and then remove the cylinder. Examine the padlock. Fracture of any component or malfunction of the padlock shall constitute failure of this test (see 3.5.2.2).

4.5.1.4 Drop test, high temperature. Support the locked padlock in a hanging position where it can be easily removed without opening the shackle. Insert a thermocouple with a temperature range of at least 0 to 1800°F (-18 to 982°C) into the keyway. Heat the body of the padlock to a temperature of 1200°F (649°C) with a heating torch. Do not concentrate the heating flame on one location, but use a brushing motion of the flame. When the thermocouple indicates 1200°F (649°C), maintain the temperature for not less than 3 minutes. Then remove the flame and lift the padlock from its support with tongs. Within 2 seconds of removing the flame, drop the padlock onto a steel plate as specified in 4.5.2.3, from a height of 3 feet (0.9 m). Immediately pick the padlock up and drop it four more times from the same height onto the same surface. If the padlock shackle opens after any drop, or opens by means other than by using the proper key, this constitutes failure of the test. Perform tests of 4.5.1.2 to determine malfunction or damage from dropping (see 3.5.2.3).

4.5.1.5 Shackle pull-out test. The test shall be conducted with the padlock at room temperature, $70^{\circ}\text{F} \pm 10^{\circ}\text{F}$ ($21^{\circ}\text{C} \pm 5^{\circ}\text{C}$). Clamp the locked padlock in a device that will bear against the shroud of the body, but not interfere with the shackle. Apply a tension load of 12,000 lbf (53,378 N) at a gradually increasing load (no sudden impact) on the vertical center line of the padlock so that a direct end equal tension is applied to each leg of the shackle. If the shackle pulls out of the padlock, it shall constitute failure of this test (see 3.5.2.4).

4.5.1.6 Low temperature shock test. Install and lock the padlock on a MIL-DTL-29181 hasp or fixture of low temperature-resistant metal that simulates the support and access of this hasp. Cold soak the padlock until the temperature is stabilized at not higher than -100°F (-73°C) and attempt to break the padlock by striking it with a 3 lb (1.36 kg) double-faced engineers hammer no less than six times. Swinging of the hammer shall be performed while grasping the end of the handle with both hands. Striking of the padlock shall be done while the padlock is within 5°F (2.8°C) of -100°F (-73°C). If the padlock opens, shatters, or fails the tests of 4.5.1.1 and 4.5.1.5 after striking for 5 minutes or less lapsed time at the low temperature, the padlock has failed the test (see 3.5.2.5).

4.5.1.7 Forced entry test. A hasp from MIL-DTL-29181 shall be secured to a solid upright post or wall supported heavy plate in a manner capable of surviving the forces of this test. The padlocks to be tested shall be locked onto the hasp. One padlock shall be tested using only non battery powered tools and one padlock shall be tested using only battery powered tools.

MIL-DTL-43607J
w/Amendment 1

4.5.1.7.1 Non battery powered tools. Any combination of non battery powered tools similar, but not limited to the following types, shall be used in an attempt to defeat the padlock. Total weight of the tools shall not be greater than 20 lb (9.07 kg).

- a. Saws, drills, and grinders – manual powered.
- b. Heating equipment – limited to single tank type, not greater than 1200 °F (649 °C).
- c. Hammer – not greater than a 3 lb (1.36 kg) weight with 18 inch (457mm) long handle.
- d. Chisels, punches, jimmys, wrecking bars, and torque levers limited to 18 inches (457 mm) in collapsed length.
- e. Common hand tools.
- f. Chemicals – capable of softening or dissolving critical components, explosives excluded.

Defeat of the padlock in less than five minutes accumulated work time (excluding preparation, rest, and safety precaution periods) shall constitute failure of this test (see 3.5.2.6.1).

4.5.1.7.2 Battery powered tools. Any combination of battery powered saws, drills, and grinders shall be used in an attempt to defeat the padlock. Total weight of the tools shall not be greater than 20 lb (9.07 kg). Defeat of the padlock in less than one minute accumulated work time (excluding preparation, rest, and safety precaution periods) shall constitute failure of this test (see 3.5.2.6.2).

4.5.1.8 Heat resistance test. Suspend a locked padlock by the shackle in an unheated oven. Turn the oven on and bring the oven temperature up to not less than 1875°F (1023°C), but not more than 1925°F (1051°C). Maintain oven temperature at 1875 °F (1023°C) for not less than 30 minutes. Turn oven off and allow the padlock to cool to room temperature. After the cooling, restrain the shackle and apply a pull of not less than 50 lb (23 kg) to the padlock body. If the shackle opens or separates from the padlock, it shall constitute failure of the test (see 3.5.2.7).

4.5.1.9 Low temperature operation test. Cold-soak the padlock at a temperature not higher (warmer) than -60°F ± 2°F (-51°C ± 1°C) for a minimum of 1 hour. While at the temperature, subject the padlock to the operational test specified in 4.5.1.14 (see 3.5.2.8).

4.5.1.10 Key integrity test. The test padlock shall be a locked padlock. The keys from 10 other padlocks selected at random from all the padlocks in the sample shall be used to attempt to unlock the test padlock. A key from each of the 10 padlocks will be fully inserted into the keyway. The key shall then be slowly withdrawn while applying a jiggling-twisting force in the direction that the lock normally opens. The padlock shall resist the withdrawing and jiggling-twisting force for 1 minute without opening. If the test padlock opens, it shall constitute failure of this test (see 3.5.3).

MIL-DTL-43607J
w/Amendment 1

4.5.1.11 Salt spray (fog) resistance test. The padlock and keys, with keys not inserted in the cylinder plug, shall be subjected to 96 hours of salt spray (fog) in accordance with ASTM B 117. After 96 hours, rinse the padlock and keys in tap water, and examine for evidence of deterioration of any component. Any evidence of deterioration, except for minor corrosion spots that obviously do not affect the performance of the padlock, shall constitute failure of this test (see 3.5.2.9).

4.5.1.12 Key hardness test. All component parts of the key shall have a hardness not less than 75 HRB in accordance with ASTM E 18 Scale B (see 3.6.3.5). If superficial hardness testing is used the superficial scale shall be equivalent to 75 HRB.

4.5.1.13 Key strength test. The manufacturer shall furnish 24 milled to shape but otherwise uncut key blanks and the depth code for each of the key cuts used by the lock. This test will establish the limit in depth of a key cut. The test facility will cut a key to the deepest biting specified by the manufacturer in the bit location closest to the key bow. The bow key ring hole will be enlarged if necessary, and a 19-inch (483 mm) length of 0.25-inch (6.35 mm) diameter, all thread rod inserted. Affix two appropriate sized nuts and washers to the rod so the key is solidly fixed at the midpoint of the rod. Clamp the key horizontally in a vise, but not past the deepest bit cut. Mark the position at the end of the rod on a fixed, immovable surface. Apply a torque force of not less than 9 lbf-in (1 Nm) to the end of the rod for not less than 30 seconds. Release the torque load and mark the position of the end of the rod. A difference of more than 0.125-inch (3.18 mm), shall constitute a failure of this test. Should a key fail, another key, cut to the next shallower key cut will be tested. The test will be repeated twice after a successful test to ensure a total of three successes. The key cut depth determined capable of passing this test for the particular keyway design used, is the deepest cut the manufacturer is to be allowed to use. If this depth differs from that which the manufacturer intended to use (see 3.4.1), the relative 100,000 unique key changes may be affected.

4.5.1.14 Operating key function test. Operate a padlock with its operating key through 10,000 cycles of the steps specified in 4.5.1.2. The cyclic procedure shall be modified so that each time the padlock is unlocked, an attempt to withdraw the key from the padlock and to rotate the cylinder plug to the control position, shall not be affected. Failure of the padlock to unlock, release of the operating key when the padlock is open, rotation of the cylinder plug to the control position, or failure of the padlock to lock shall constitute failure of this test. If the keyway cover or plate does not remain aligned with the keyway or obstructs the insertion of the operating key into the keyway, it shall also constitute failure of this test. The test shall be performed before and after 4.5.1.9 (see 3.6.3.11 and 3.6.4.1).

4.5.1.15 Control key function test. Use the control key to turn the cylinder plug to the unlocked position and then to the control position. If the control key does not turn the cylinder plug to both unlock and control positions, or cannot be used to remove and reinsert the cylinder assembly, it shall constitute failure of this test (see 3.6.3.2 and 3.6.3.12).

MIL-DTL-43607J
w/Amendment 1

4.5.1.16 Cylinder interchangeability test. Remove the cylinder assembly from one padlock. Use the control keys of other padlocks from the same lot sample to remove their cylinder assemblies and to insert them into the padlock from which the cylinder has been removed. Then operate the padlock through not less than 5 cycles of the steps specified in 4.5.1.2, using the operating key which matches that of the cylinder. If the padlock fails to lock and unlock using each of the replacement cylinder assemblies and their associated keys, it shall constitute failure of this test (see 3.6.3.3).

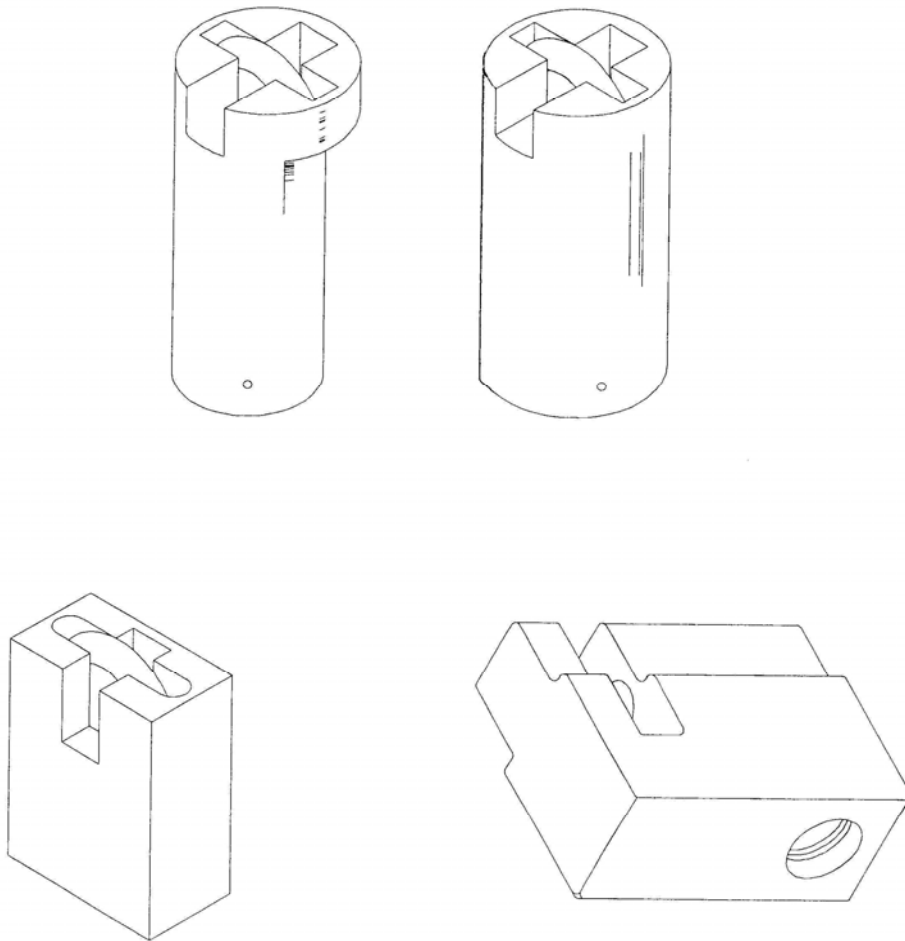

FIGURE 1. Example of padlocks with shrouded shackles.

MIL-DTL-43607J
w/Amendment 1

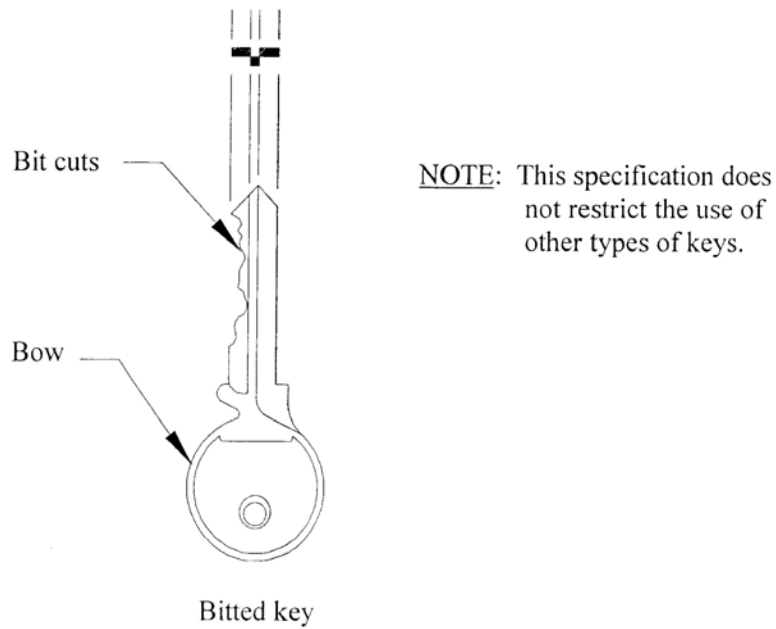
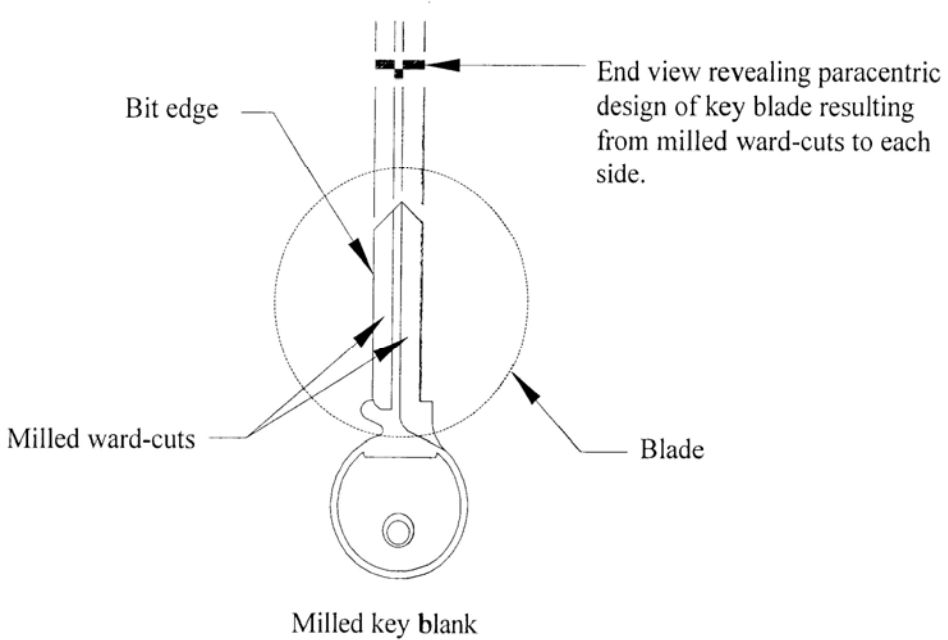

FIGURE 2. Key nomenclature.

5. PACKAGING

5.1 Packaging. For acquisition purposes, the packaging requirements shall be as specified in the contract or order (see 6.2). When actual packaging of materiel is to be performed by DoD or in-house contractor personnel, these personnel need to contact the responsible packaging activity to ascertain requisite packaging requirements. Packaging requirements are maintained by the Inventory Control Point's packaging activity within the Military Department or Defense Agency, or within the military services system commands. Packaging data retrieval is available from the managing military Department's or Defense Agency's automated packaging files, CD-ROM products, or by contacting the responsible packaging activity.

6. NOTES

(This section contains information of a general or explanatory nature that may be helpful, but is not mandatory.)

6.1 Intended use. The padlock covered by this specification is intended for general military use with hasps conforming to MIL-H-24653, MIL-DTL-29181, and drawings listed in 3.4 herein, where a high degree of physical security is required. The degree of security is reduced when the padlock is used without a high security hasp.

6.2 Acquisition requirements. Acquisition documents must specify the following:

- a. Title, number, and date of this specification.
- b. Key requirements, if different (see 3.1 and 3.2).
- c. When a first article is required for inspection and approval, and the number of units required and instructions for disposition, if different (see 3.2 and 4.3).
- d. Packaging requirements (see 5.1).

6.3 First article. When first article testing and approval is required, the first article units will be selected and tested as specified in 3.2 and 4.1. The contracting officer should include specific instructions in acquisition documents regarding arrangements for examination, tests, availability of drawings of hasps required for tests, source(s) to purchase hasps for tests, disposition of bid sample and first article units tested, and approval of the first article.

6.4 Sampling procedures.

6.4.1 Sampling for examination. Recommended inspection level is S-3 (see 4.4.1.1).

6.4.2 Sampling for tests. Recommended inspection level is S-3 (see 4.4.1.2).

6.5 Subject term (key word) listing.

Chemicals
Control key
Cylinder
Key, control
Keyway
Keyway military
Operating key
Physical security
Physical security devices
Physical security hardware

6.6 Amendment notations. The margins of this specification are marked with vertical lines to indicate modifications generated by this amendment. This was done as a convenience only and the Government assumes no liability whatsoever for any inaccuracies in these notations. Bidders and contractors are cautioned to evaluate the requirements of this document based on the entire content irrespective of the marginal notations.

Custodians:
Navy - YD
Air Force - 99

Preparing Activity:
DLA-IS

(Project 5340-2010-020)

Review Activities:
Navy – AS, CG, NO

NOTE: The activities listed above were interested in this document as of the date of this document. Since organizations and responsibilities can change, you should verify the currency of the information above using the ASSIST online database at <https://assist.daps.dla.mil>.